

#1	1:29
Gauge	SCALE

VANDERBILT TENDER

INSTRUCTION MANUAL

ART-21850 - 01

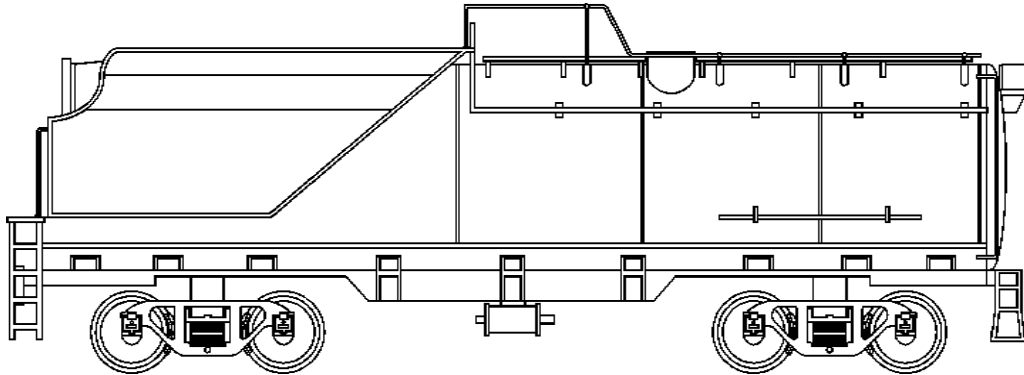

ARISTO-CRAFT TRAINS

110502 NEW

ARISTO-CRAFT TRAINS

Dear Model Railroader,

This Vanderbilt Tender is a highly detailed #1 Gauge 1/29th scale unit and is suitable for both indoor and outdoor operation. It has been manufactured to our usual high specifications.

Should you have any questions regarding operation, proper usage or maintenance required on this or any other Aristo-Craft product, please do not hesitate to contact us at the following address:

ARISTO-CRAFT TRAINS / Polk's Modelcraft Hobbies, Inc.

698 South 21st Street, Irvington, NJ 07111 USA

Tel: (973) 351-9800 Fax: (973) 351-9700

e-mail: aristo@mindspring.com

Our customer service department phones are open from 10:00 AM to 5:00 PM Eastern time, Monday through Friday.

Visit our website: www.aristocraft.com

HISTORY

The Vanderbilt Tender was unique in that it has a cylindrical body rather than the more usual square body type. It was developed at the turn of the 20th century and was the preferred tender for several railroads. In the East, the Baltimore & Ohio, Chesapeake & Ohio, New Haven and Erie Railroads used many of these tenders. In the West, the Southern Pacific, Union Pacific and the Great Northern were frequent employers of Vanderbilt Tenders. One reason for its preference is that for its length, a cylindrical object is stronger than a rectangular object.

FEATURES

This tender has the following features, which make it look and operate in a superior manner:

Highly Detailed Body and Fuel Bunker

Metal Wheels

Electrical Pickup from the Rear Truck

Operating Back Up Light

Blackened Brass Grab Irons and Hand Rails

Operating Knuckle coupler on the Rear

Sprung and Equalized 4 Wheel Trucks

Speaker for Sound Factory Installed

Sound Ready

Poly Switches to Prevent Short Circuits
in Case of Derailment

SOUND INSTALLATION

This tender is equipped with a factory installed speaker and male plugs for the installation of a sound board. These plugs are located on a small PC board in front of the speaker, on the tender floor (see drawing below). The 3 pin plug is for the speaker, the 2 pin plug is for power. Purchase the sound system of your choice and install it according to the manufacturers instructions. To gain access to the speaker and PC board, it is necessary to open the tender. Slightly spread the bottom front of the fuel bunker sides and pull up. The sides and top of the fuel bunker will pull free and expose the interior of the tender.

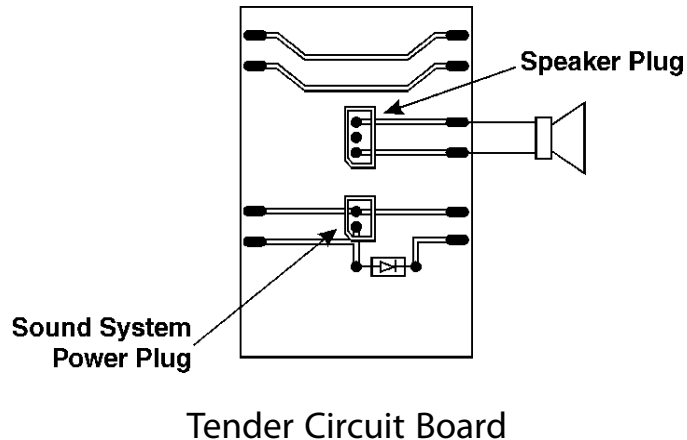

MODULAR PLUGS

There are 2 modular plugs in the front of the tender, one large and one small. A large modular plug is also installed at the rear of the tender. The large plugs are used for battery operation, if so desired. See the section regarding battery operation in the locomotive manual. The smaller plug transmits power from the tender pick up to the locomotive. Be sure that the locomotive and tender plugs are attached.

WHEELS

The tender wheels are metal and the rear two are used for electrical pick up. Over a period of time these wheels may require cleaning. Dirty wheels will cause sporadic electrical pick up which is indicated by flickering lights. In order to properly clean the wheels, remove the tender from the track and turn it upside down to expose the wheels. The Crest CRE-29601, Smoke Fluid is also a very good track and wheel cleaner. Apply with a soft, clean rag and wipe the dirt away. **Never use abrasives to clean wheels**, as the resulting minute scratches retain dirt easier.

COUPLERS

An operational knuckle coupler is attached to the rear of the tender. This coupler is prototypically correct and may be operated manually by pressing upward on the small tab below the coupler assembly. Automatic uncoupling may be accomplished by using an LGB* designed uncoupling device.

**(LGB is a trademark of the E.P. Lehmann Company, Germany).*

OPERATION

This tender, when coupled to a locomotive or cars, requires a minimum track diameter of 8'. Smaller diameter curves may cause derailments and clearance problems. Smaller curves will also cause cars coupled to the tender to be pulled completely off of the rails.

LIMITED WARRANTY

All ARISTO-CRAFT TRAINS products are under warranty for five (5) years from the date of purchase against defects in workmanship and/or materials. Proof of purchase *may be required* by ARISTO-CRAFT TRAINS.

This warranty is void and does not apply to any product and/or parts and components which have been improperly installed by the purchaser/owner, abused or damaged in any way through improper operation such as but not limited to derailment, repairs or modifications performed by non-authorized service centers or technicians.

SERVICING

Should your ARISTO-CRAFT TRAINS product require warranty service, please return it in the original box, if possible, protected by a proper shipping carton. Send the product fully insured and prepaid. ARISTO-CRAFT TRAINS will not be responsible for any loss or damage incurred during shipping. Be sure to include a brief, but thorough explanation of the problem, together with your name, street address (no Post Office box please), city state or province and country, if outside of the United States. Also include a daytime telephone number so that we may contact you if necessary. Your return address should be clearly marked on the outside of the shipping carton.

Payment for shipping and handling, in U.S. funds, is \$20.00 and should be included. Your check or money order should be made payable to: Polk's Modelcraft Hobbies, Inc. Do not send cash. If your item is not covered by warranty service, you will be contacted and a repair estimate given before any work commences. Warranty covers manufacturer defects, not normal wear and tear.

The shipping address to be used for returns is as follows:

ARISTO-CRAFT TRAINS / Polk's Modelcraft Hobbies, Inc.
Customer Service Department
698 South 21st Street
Irvington, NJ 07111 USA
Tel: (973) 351-9800

Written confirmation of receipt of returned items will be sent with estimated repair time by the ARISTO-CRAFT TRAINS Customer Service Department.