

ART7104 OVER & UNDER TRESTLE SET (26 PIECES)
ART7106 12 PC. TRESTLE SET 8 1/2"

INSTALLATION

1. Apply plastic cement before in serting legs on trestles, Do not attempt to remove legs after glue is hardened. (Fig 1)

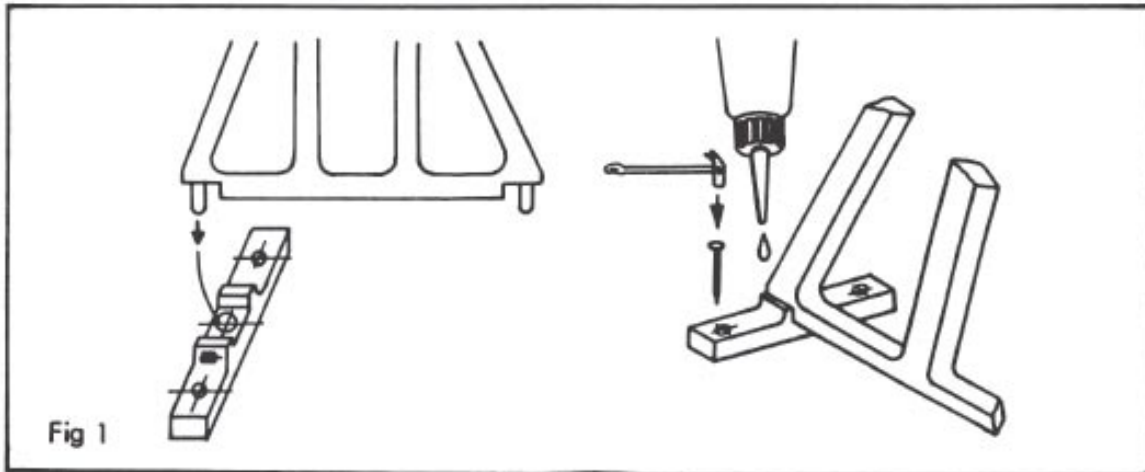

If the floor is wooden and you wish to firmly install the trestle please use the hole on the legs to drive in the nails (not provided)

2. Please note that all trestles except # 11 are tapered to an angle, which must be placed correctly to match the slope of the tracks. (Fig 2)

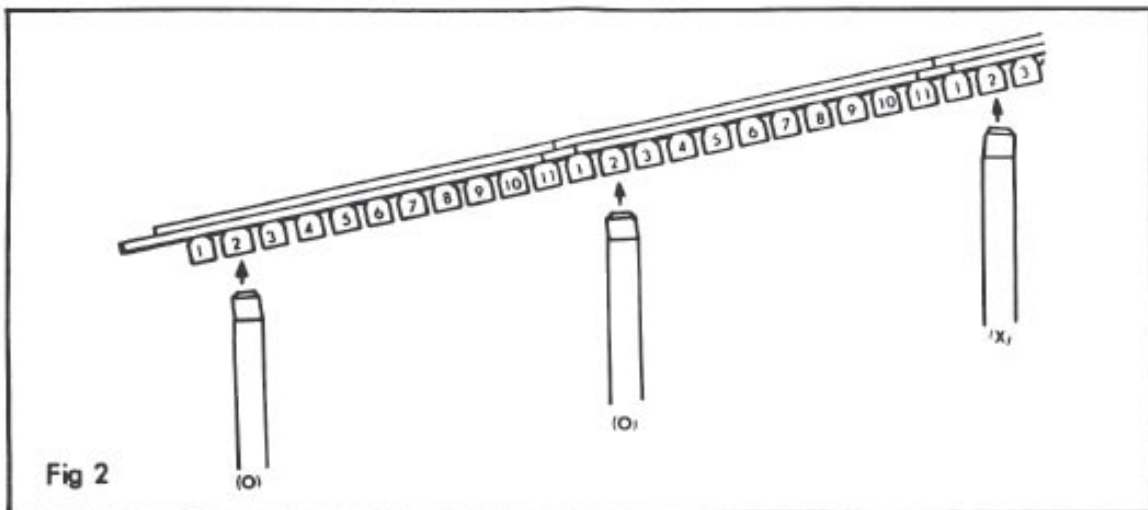

3. FIGURE EIGHT INSTALLATION EXAMPLE

Install on the second tie to maintain same slope. (Fig 3)

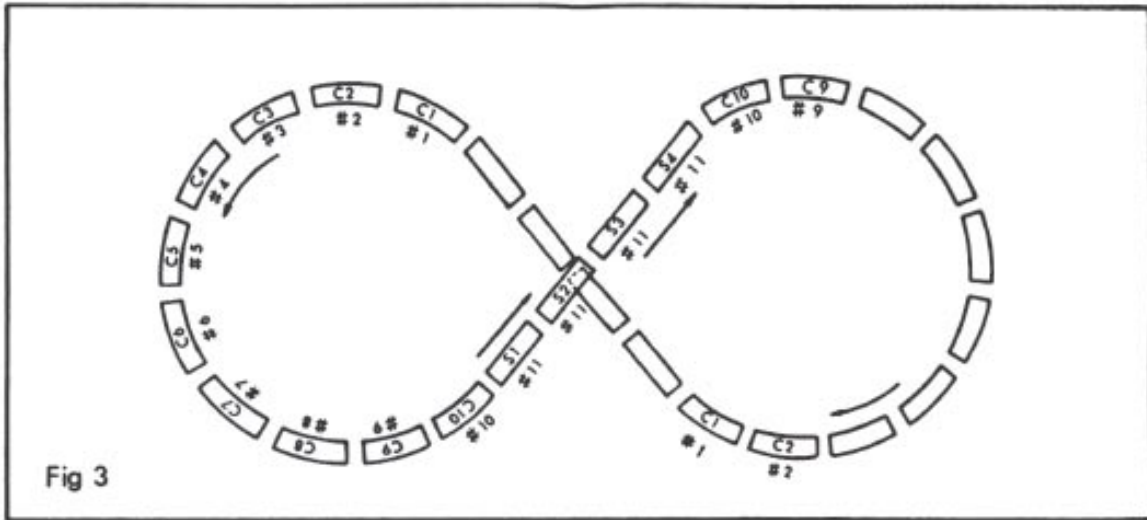

(NOTE) C = Curved Track
S = Straight Track

Generally, install the trestles on the second ties to maintain steady slope. However, depending on the terrain this can be modified according to your judgment.

ART7108 BRASS TRESTLE SUPPORTS

The trestle support is an optional item sold separately that may be used when you desire to have more secured tracks, but the installation location is not suitable to use nails as described in (Fig 1).

You will find that support holes are only available from trestle # 6~ # 11. (Fig 4)

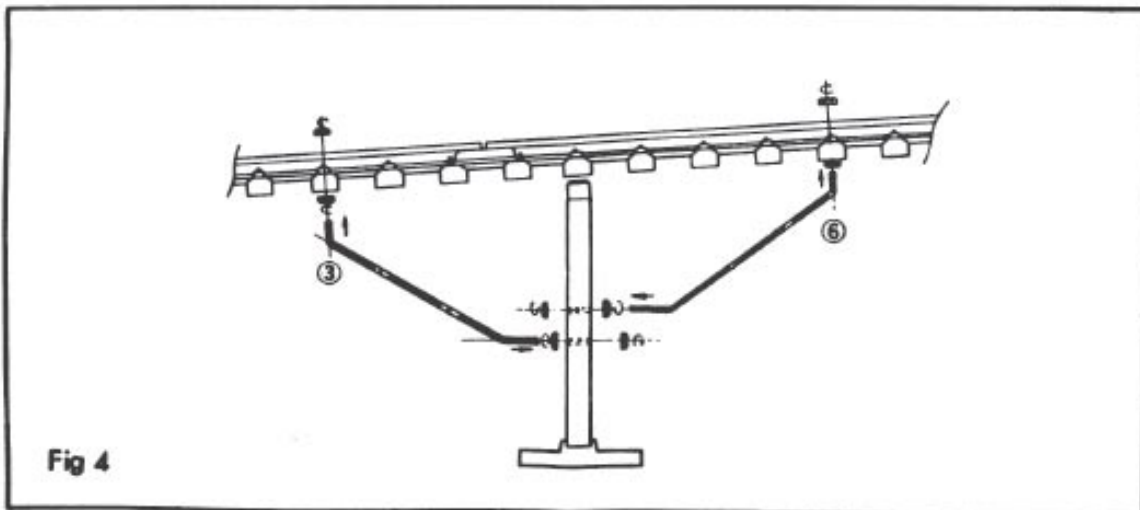

SERVICE:

Should your ARISTO-CRAFT TRAINS model railroad product require warranty service, be sure to take the following steps to assure proper servicing:

1. Return product in ORIGINAL BOX, if not possible to use original box, pack product carefully in corrugated cardboard box, FULLY INSURED and PREPAID. ARISTO-CRAFT TRAINS will not be responsible for any damage or loss incurred during shipping.

2. Include a brief but thorough explanation of the problem(s) and the servicing that may be required.

3. Be sure to include your name, street address, city, state (or province), country (if outside U.S.A.), and postal zipcode along with daytime phone number including Area Code, so that you may be contacted if it becomes necessary. All identification MUST be both - INSIDE package, enclosed in letter and - OUTSIDE package, on shipping container.

4. Include proper payment for shipping/handling -

CALL FOR CURRENT SHIPPING COSTS

- with check/Money Order payable in US dollars \$ to : Polk's Hobbies. Please DO NOT SEND CASH. If your item is out of warranty, you will be contacted with the proper amount of repair costs before repairs are started.

*** C.O.D. shipping NOT included, additional cost.***

5. Ship your items(s) to:

ARISTO-CRAFT TRAINS
698 SOUTH 21ST STREET
IRVINGTON, NJ 07111
PHONE: 973-351-9800
FAX: 973-351-9700
EMAIL: aristo@mindspring.com
www.aristocraft.com

Note: Immediate written confirmation of receipt of returned item(s) will be sent along with estimated repair time by ARISTO-CRAFT TRAINS Service/Repair department.