

ARISTO-CRAFT TRAINS
698 SOUTH 21ST STREET
IRVINGTON, NJ 07111

PHONE: 973-351-9800
FAX: 973-351-9700
EMAIL: aristo@mindspring.com
www.aristocraft.com

Wiring Diagrams for the "On-Board-Receiver" (ART-5490)

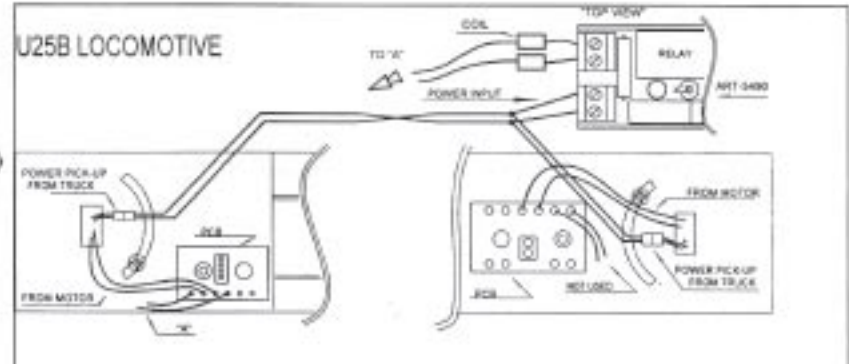

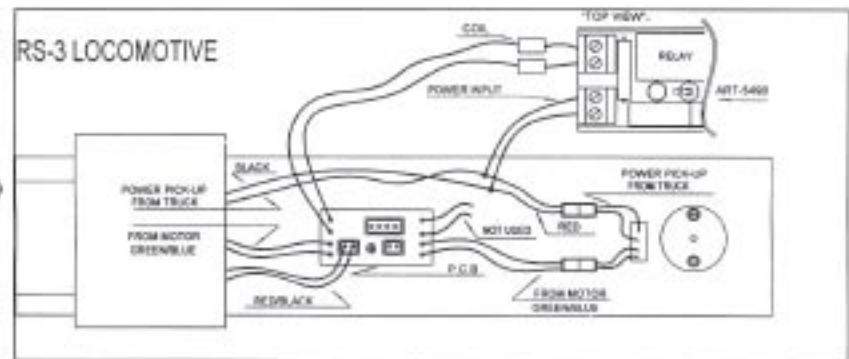
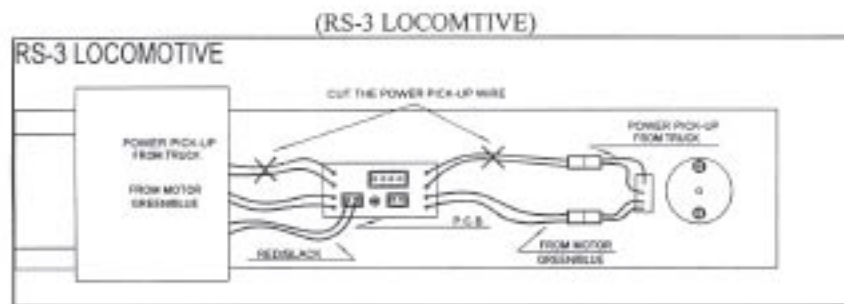
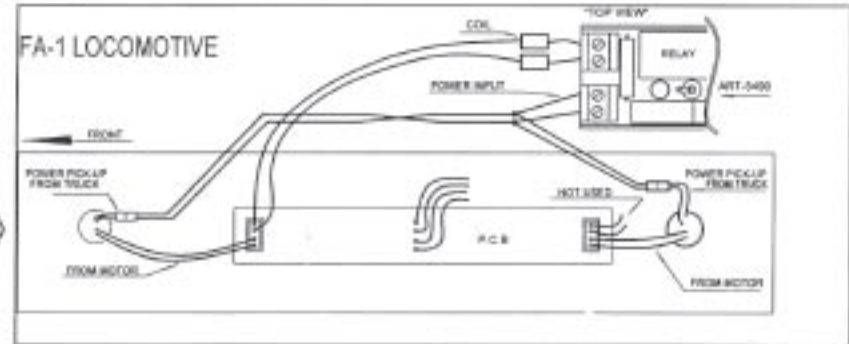
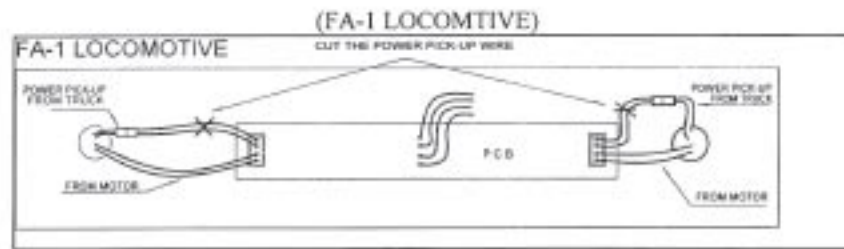
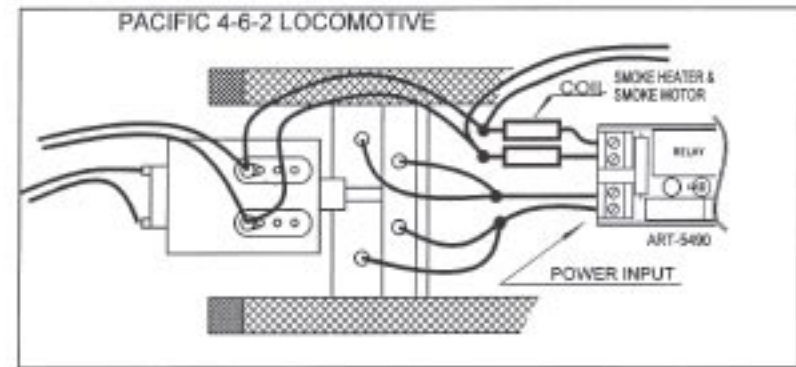
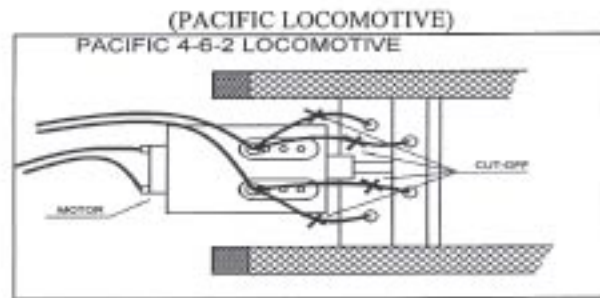

(2-4-2 ROGERS LOCOMOTIVE)

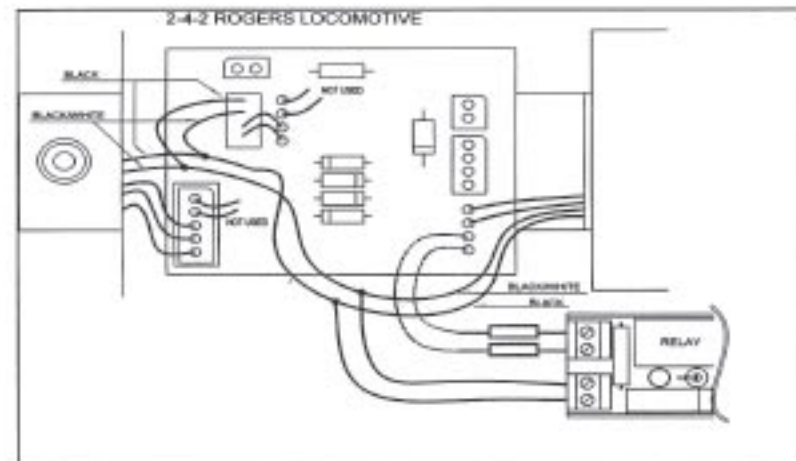
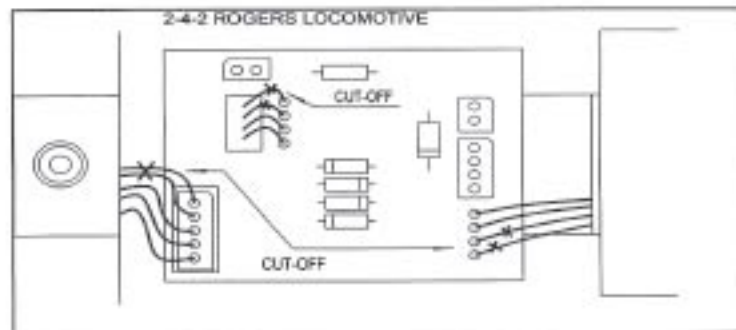

TYPICAL WIRING DIAGRAM FOR OTHER LOCOMOTIVES

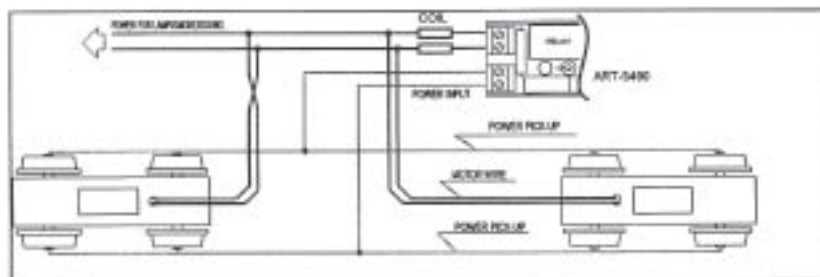

Note:

Please note that it is important that the output wires, from the receiver to the motor, be dressed away from the receiver unit. It is also important that the antenna wire be kept away from power sources, including but not limited to motors, sound systems and their speakers, and other printed circuitry. All of the wires should be held in place with tape in order to keep them from shifting.

*PCB: Printed Circuit Board